



Features

- 10.1" Food Industrial Panel PC
- Flat front panel touch screen
- Fanless design
- Intel Celeron N2930
- Onboard 4GB DDR 3L 1600 MHz
- Wide range DC 9~36V power input

Specifications

System	
CPU	Onboard Intel Celeron N2930 Processor (2M Cache, 1.83GHz)
System Chipset	SoC
Memory	Onboard 4GB DDR3L SDRAM

IO Port	
USB	2 x USB 3.0 type A
Serial/Parallel	1 x RS-232/422/485 DB-9, default RS-232(COM1) 1 x RS-232 DB-9(COM2)
Audio	1 x Line Out
LAN	2 x GbE LAN RJ-45
Power	1 x 3-pin terminal block connector 1 x 2-pin Power Switch connector

Storage Space	
HDD	1 x 2.5" SATA HDD space (Easily Accessible)
movable device	1 x internal SD slot onboard

Expansion	
Expansion Slot	1 x Mini-PCIe (full size)

Display	FABS-810P	FABS-810PH
Display Type	10.1" TFT-LCD	10.1" TFT-LCD
Max. Resolution	1280 x 800	1280 x 800
Max. Color	16.7M	16.7M
Luminance (cd/m ²)	350	1000
Viewing Angle(H°/V°)	170/ 170	170 / 170
Contrast Ratio	800 : 1	1000 : 1
Backlight Lifetime(hrs)	25,000	50,000

Touch Screen	
Type	Projected Capacitive Touch
Interface	USB interface
Light Transmission(%)	over 90%

Power	
Power Input	DC 9~36V
Power Consumption	FABS-810P: 14W

Dimensions

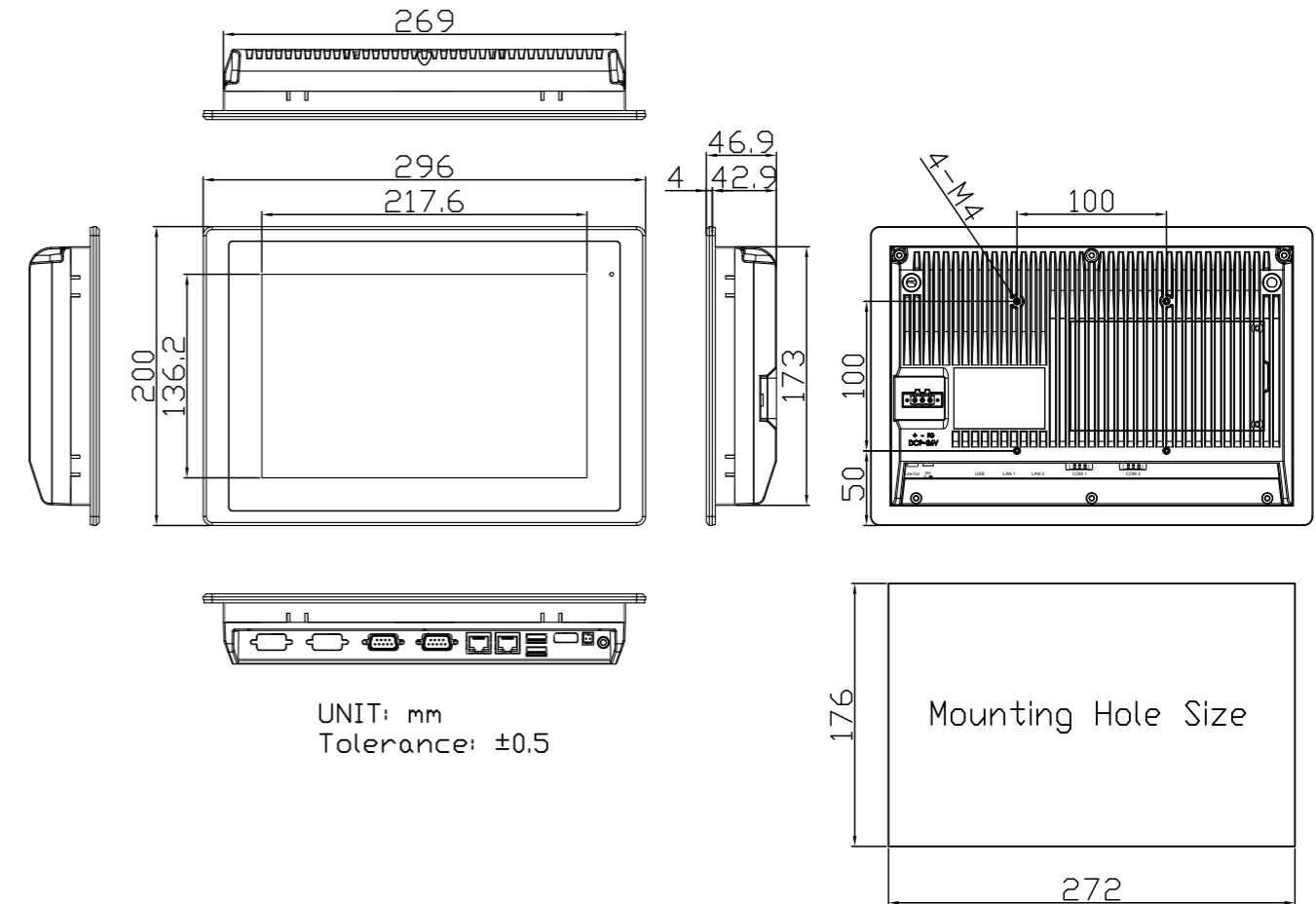

Mechanical	
Construction	304 Stainless steel front bezel (Default) 316 Stainless steel front bezel (option) Aluminum back cover
Mounting	Panel mount, VESA mount 100 x 100
IP Rating	IP66/IP69K compliant front bezel
Dimensions(mm)	296 x 200 x 47
Net weight(Kgs)	1.9

Environmental	
Operating Temperature	0~50°C (-20~60 option)
Storage Temperature	-30~70°C
Storage Humidity	10 to 90% @ 40°C, non-condensing
Certificate	CE / FCC Class A/EN 1672-2

Operating System Support	
Windows embedded 7	
Windows embedded 8.1	
Windows 10 IoT ENT LTSC	

Ordering Information	
FABS-810P (Barebone)	10.1" WXGA fanless HMI barebone with Celeron N2930 (1.83.GHz) CPU, 4GB DDR3L RAM, Projected Capacitive touch, 9~36VDC input with adapter, Stainless front bezel and Aluminum chassis.